

Flat Pattern view
SCALE: 1:2

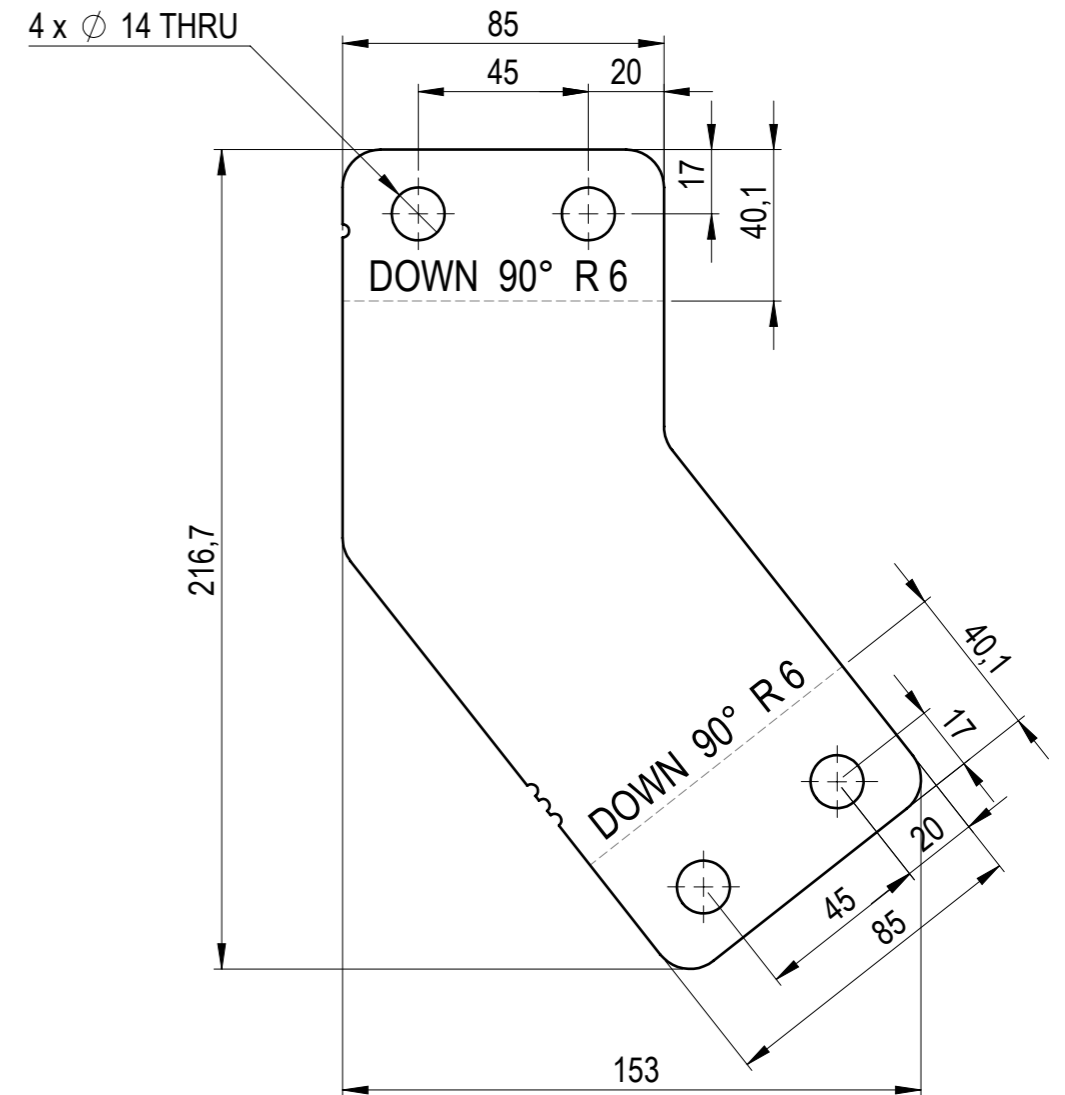

Other dimensions from .DXF file.

SHEET METAL INFORMATION	
Length, mm	233
Width, mm	116.5
Thickness, mm	6
Inside Bend Radius, mm	6
K-Factor	0.5
No. of Bends	2

WEMPS ENGINEERING SERVICES	MATERIAL	WEIGHT	DEBURR AND BREAK SHARP EDGES	REVISION	DATE
	S355J2	0.852 Kg	DO NOT SCALE DRAWING		29.05.2025
	SURFACE PROTECTION	MACHINING	THERMAL CUTTING	WELDING	SCALE
	HDG EN ISO 1461	ISO 2768 mK	ISO 9013 221	ISO 13920 BF	1:2
	NAME	SIGNATURE	PART NO.		FORMAT
Designed by	D. Dislers		105-09100-73		A3
Drawn by	D. Dislers		DESCRIPTION		
Technical ref.			Left bracket C2-U		
					SHEET 1/1